



FULLY AUTOMATIC SOFT LOOP HANDLE BAG, DRAW TAPE BAG, DIE CUT BAG & PATCH HANDLE BAG MAKING MACHINE WITH SERVO MOTOR CONTROL

CW-800PFM-SV

CW-1000PFM-SV



ISO-9001

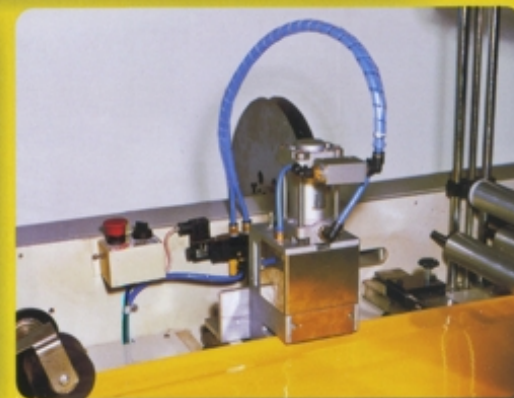

CHAO WEI PLASTIC MACHINERY CO., LTD.



CHAO WEI PLASTIC MACHINERY
CHAO WEI PLASTIC MACHINERY

CHAO WEI PLASTIC MACHINERY
CHAO WEI PLASTIC MACHINERY

CHAO WEI PLASTIC MACHINERY
CHAO WEI PLASTIC MACHINERY

CHAO WEI P

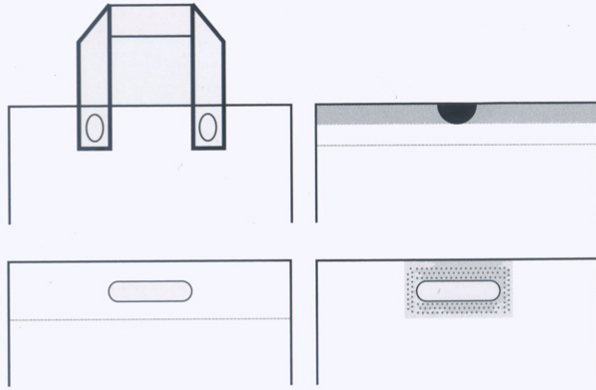

CW-800PFM-SV



- OPTIONAL EQUIPMENT:**
1. Triangle Folding Equipment
 2. May choose mono-function specific machine
 3. EPC control

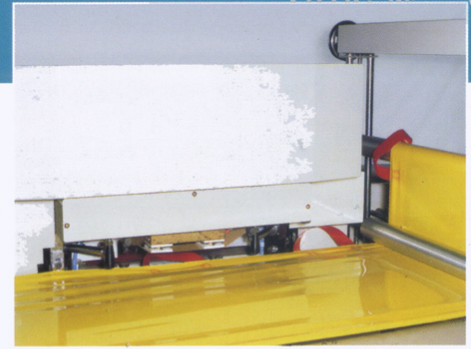
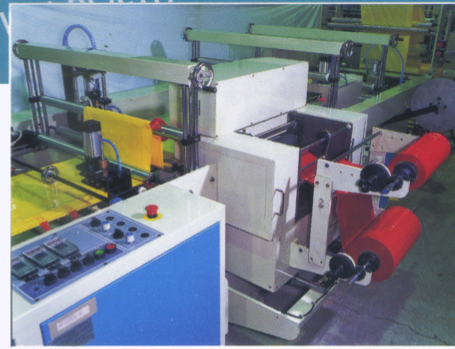
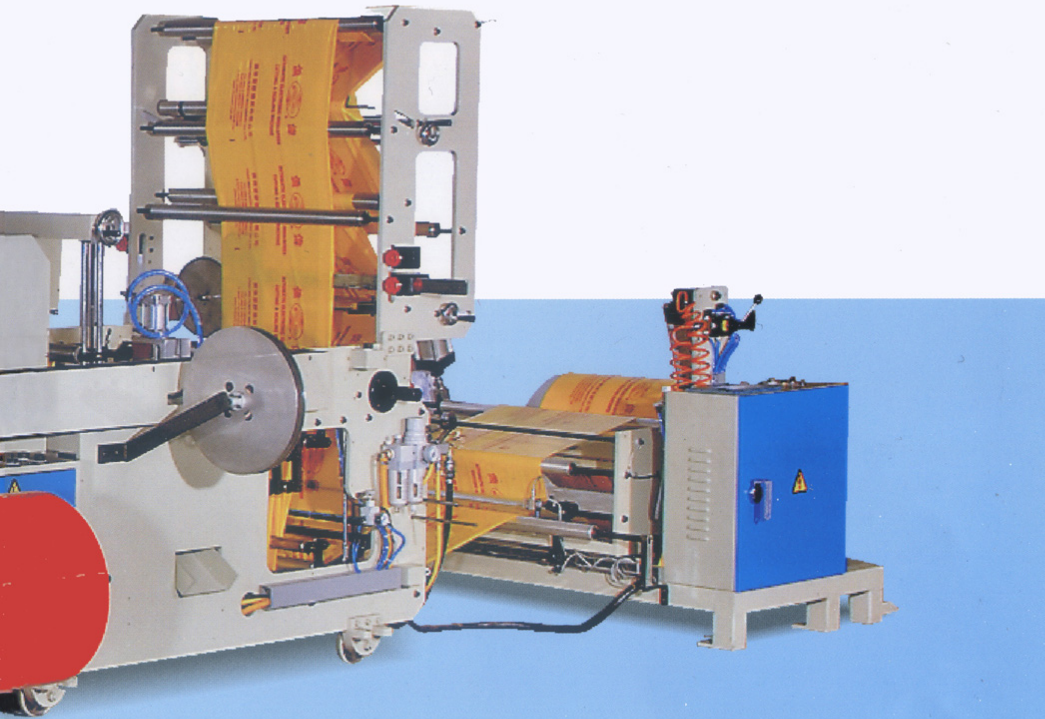

SOFT LOOP HANDLE SHOPPING BAG

At the rear one unwind station for the polyethylene film. The film width is identical to the loop length. The film is cut into narrow strips, and fed into the top fold. The flexible handle film feeding system is driven by pneumatic control. The roll of the film is fed, cut and welded automatically and is precisely positioned to the center of the shopping bag.

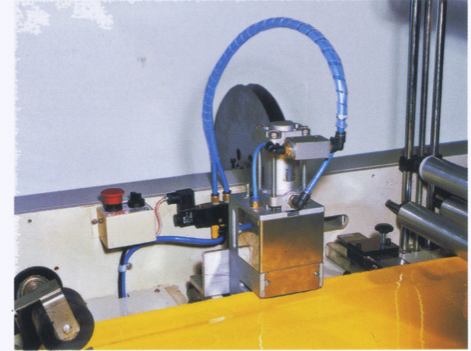
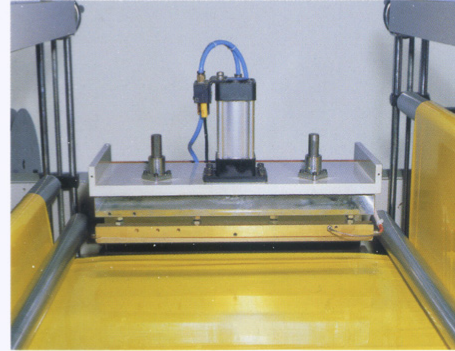

DRAW TAPE BAG

The film for the draw tape handle should be pre-slit to width and automatically fed into the top folds of the bag by special forming tool.

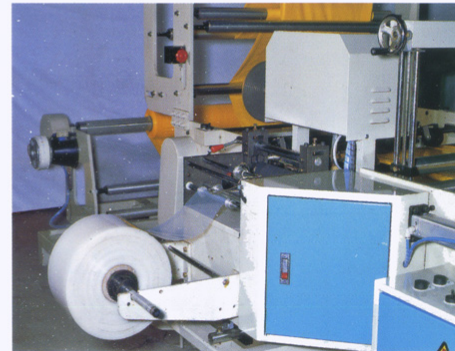

PATCH HANDLE BAG

The patch handle film feeding system is pneumatically. The reel of patch film is fed, cut and welded automatically to the top central position of the PE bag.

EPC CONTROL:

Adopt photo eye to track EPC system, easily operation to control both thick & thin film. Without noise & dirty fault of hydraulics.

SPECIFICATION: 規 格

型 式 MODEL	切袋寬 BAGS WIDTH	切袋長 BAGS LENGTH	封切厚度 CONVERTING THICKNESS	頂 封 TOP FOLDING	底 摺 BOTTOM GUSSETING	封切速度 P.C.S. /MIN	動力 MOTOR /HP	電 熱 HEATER (KW)	全台備電 POWER REQUIRED	機 械 尺 寸 DIMENSION L×W×H(M)	機 械 重 量 MACHINE WEIGHT(kg)	裝 箱 重 GROSS WEIGHT(kg)
CW-800PFM-SV	250 ~ 650 m/m	250 ~ 650 m/m	0.045 ~ 0.1 m/m	70 ~ 75 m/m	70 ~ 75 m/m	40 ~ 70	2	1.8 kw×1 0.8 kw×2 0.4 kw×6	8.5 KW	8.0×2.3×2.0	3500	5000
CW-1000PFM-SV	250 ~ 650 m/m	250 ~ 850 m/m	0.045 ~ 0.1 m/m	70 ~ 75 m/m	70 ~ 75 m/m	40 ~ 70	2	1.8 kw×1 0.8 kw×2 0.4 kw×6	10 KW	8.0×2.5×2.0	4200	5700

● Due to continuous research and development, specifications are subject to further revision without prior notice.

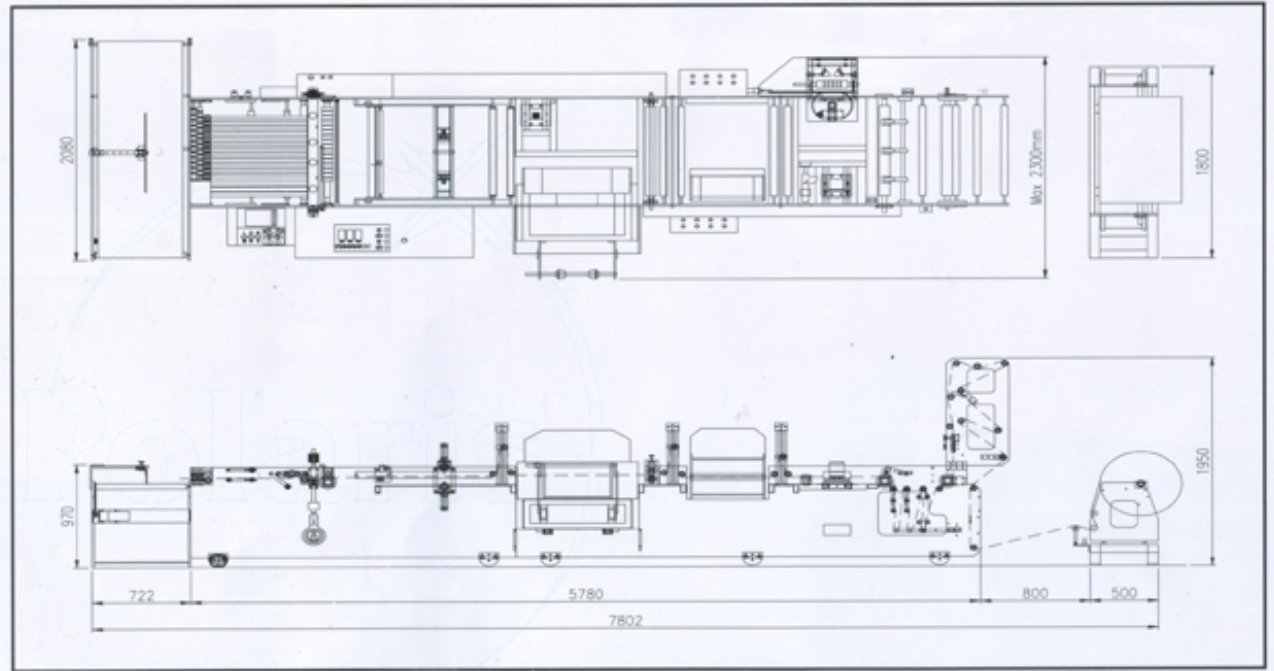

ISO-9001 FM40584

僑偉塑膠機械有限公司
CHAO WEI PLASTIC MACHINERY CO., LTD.

公 司: 嘉義縣水上鄉大堀村大堀尾1-12號
NO. 1-12, TA CHUEH WEI, TA CHUEH TSUN, SUEI
SANG HSIANG, CHIA YI HSIEN, 60842 TAIWAN.

TEL: 886-5-2686688 . 2686677

FAX: 886-5-2682288 . 2687821

E-mail: chao.wei@msa.hinet.net

http://www.chaowei.com.tw

Free Machinery CD-Roms are available upon request